

CP 7-6

Multi purpose AGM battery

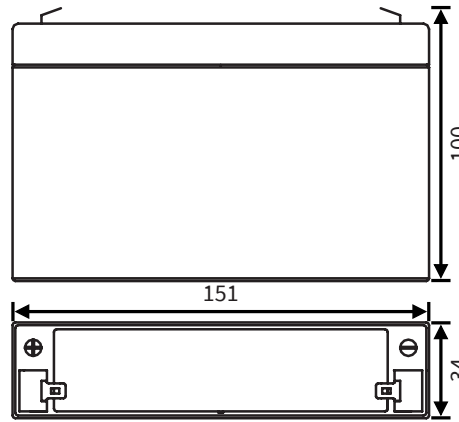

Dimensions (mm)



Standard terminal (mm)

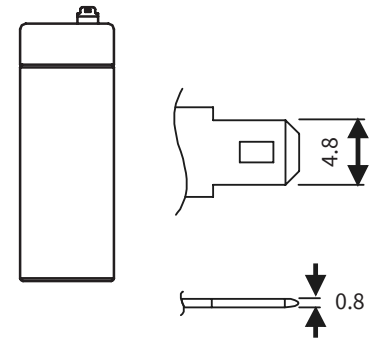

Typical applications

- Security systems
- Measuring equipment
- Emergency lighting
- UPS systems
- Telecom systems
- Medical equipment
- Control panels
- Electronic instruments

Features

- Valve Regulated Lead Acid (VRLA)
- Absorbent Glass Mat Technology (AGM)
- High current drain grid resistant to corrosion by virtue of a lead-calcium alloy
- Maintenance free
- Classified as non-spillable under IATA, ADR and IMDG regulations
- Can be discharged or stored in any position without leakage
- Battery cannot be charged while upside down
- Produced under ISO 9001 & ISO 14001

Nominal voltage	6 V
Nominal capacity (1.70V/c, 25°C)	20Hr: 7.2 Ah
	5Hr: 6.15 Ah
	1Hr: 4.49 Ah
Internal resistance	≤16mΩ (fully charged)
Maximum charge current	2.16 A
Maximum discharge current	108 A (max. 5 sec)
Float use / cyclic use	6.80 - 6.90V / 7.25 - 7.45V
Charge temperature range	-10°C ~ 50°C
Discharge temperature range	-15°C ~ 50°C
Design life (20°C)	3-5 years (Eurobat)
Standard terminal	Faston 4.8mm (T1)
Housing material	ABS (UL94-HB)
Dimensions Length	151 mm
Dimensions Width	34 mm
Dimensions Height	100 mm
Approximate Weight	1.15 kg
Packing	10 pcs / box

Constant Current Discharge (Amps) at 25°C (77°F)

F.V/TIME	5 Min	10 Min	15 Min	30 Min	60 Min	2 Hr	5 Hr	10 Hr	20 Hr
1.80V/cell	23.0	14.5	11.8	6.82	4.27	2.42	1.19	0.66	0.35
1.75V/cell	24.4	15.4	12.4	7.07	4.40	2.48	1.22	0.67	0.36
1.70V/cell	25.4	16.1	12.9	7.25	4.49	2.52	1.23	0.67	0.36
1.65V/cell	26.5	16.8	13.4	7.48	4.61	2.54	1.24	0.68	0.36
1.60V/cell	27.4	17.3	13.7	7.63	4.68	2.56	1.25	0.68	0.37

Constant Power Discharge (Watts) per Cell* at 25°C (77°F)

F.V/TIME	5 Min	10 Min	15 Min	30 Min	60 Min	2 Hr	5 Hr	10 Hr	20 Hr
1.80V/cell	21,33	13,65	11,18	6,517	4,117	2,367	1,182	0,657	0,353
1.75V/cell	22,67	14,45	11,80	6,750	4,250	2,417	1,218	0,670	0,360
1.70V/cell	23,67	15,10	12,22	6,917	4,333	2,450	1,227	0,673	0,362
1.65V/cell	24,67	15,75	12,68	7,150	4,450	2,483	1,235	0,677	0,363
1.60V/cell	25,50	16,25	13,00	7,283	4,517	2,500	1,242	0,680	0,365

*: Battery consists of 6 cells

Charge characteristics

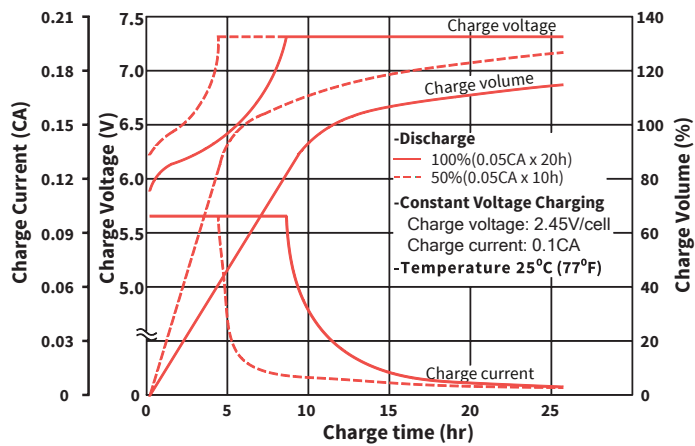

Discharge characteristics

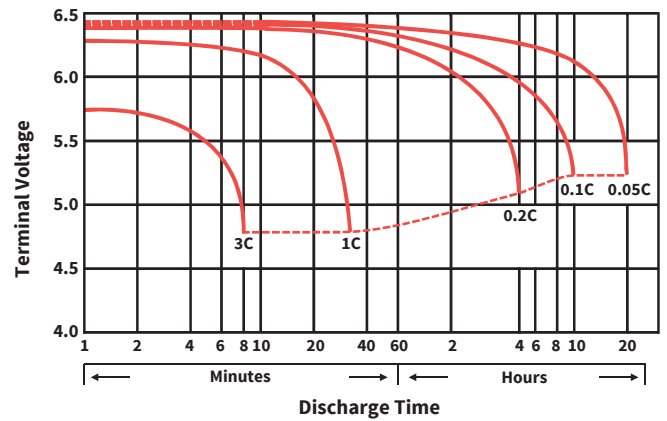

Charge voltage in relation to temperature

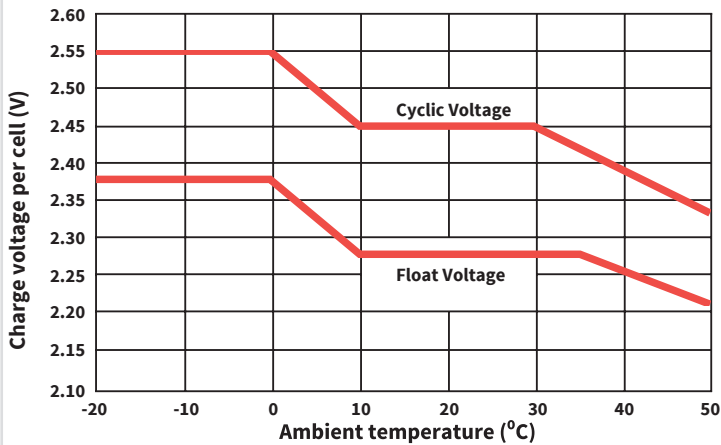

Service life in relation to temperature

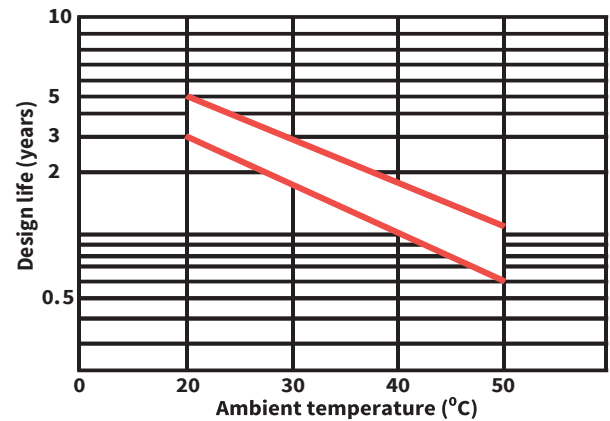

Models available

Model	Voltage	Capacity (Ah)	Dimensions (mm)	Weight (kg)
CP 1.2-6	6	1.2	97x24x58	0.28
CP 3.2-6	6	3.2	134x35x67	0.60
CP 3.5-6	6	3.5	194x25x56	0.60
CP 4-6	6	4.0	70x47x107	0.68
CP 7-6	6	7.0	151x34x100	1.15
CP 12-6	6	12	151x50x100	1.80
CP 0.8-12	12	0.8	96x25x62	0.40
CP 1.2-12 *	12	1.2	97x43x58	0.52
CP 2-12M	12	2.0	150x20x90	0.68
CP 2.2-12 *	12	2.2	178x34x66	1.04
CP 2.9-12	12	2.9	79x56x105	1.05
CP 3.2-12 *	12	3.2	134x67x67	1.30
CP 4.5-12	12	4.5	195x47x76	1.58
CP 7-12 *	12	7.0	151x65x102	2.20
CP 7-12L *	12	7.0	151x65x102	2.20
CP 12-12 *	12	12	151x98x98	4.02
CP 18-12I *	12	18	181x76x167	5.60
CP 20-12B	12	20	181x76x167	5.95
CP 26-12I *	12	26	166x175x125	9.30
CP 40-12I *	12	40	197x165x170	12.80
CP 65-12 *	12	65	350x167x179	20.80

*: VdS approved battery

VdS approved VRLA batteries

The VdS-approved Cellpower batteries form a special range that has been tested and qualified by the German VdS institute. The concept behind VdS recognition; ensuring tested and certified quality in the products and services being offered in the safety and security markets, is of equally advantageous for user and supplier. Safety and security systems are approved by the VdS and monitored in subsequent use to protect property and life and help to keep a insurance premiums lower.

Typical applications:

- VdS approved alarm systems
- Fire & burglar alarm systems

Cellpower family

Cellpower supplies a broad range of reliable AGM, GEL and Lithium batteries. Each product series has its own unique characteristics, so that there is a suitable battery for every application with its associated specific usage profile. Combined with the right Cellpower battery accessories, you are able to assemble a high-quality and reliable battery system.

